

# ON-SITE GUARDRAIL GARDEN TRAINING

## SRT-31 End Treatment Component Checklist

Date Created: 4/1/2024

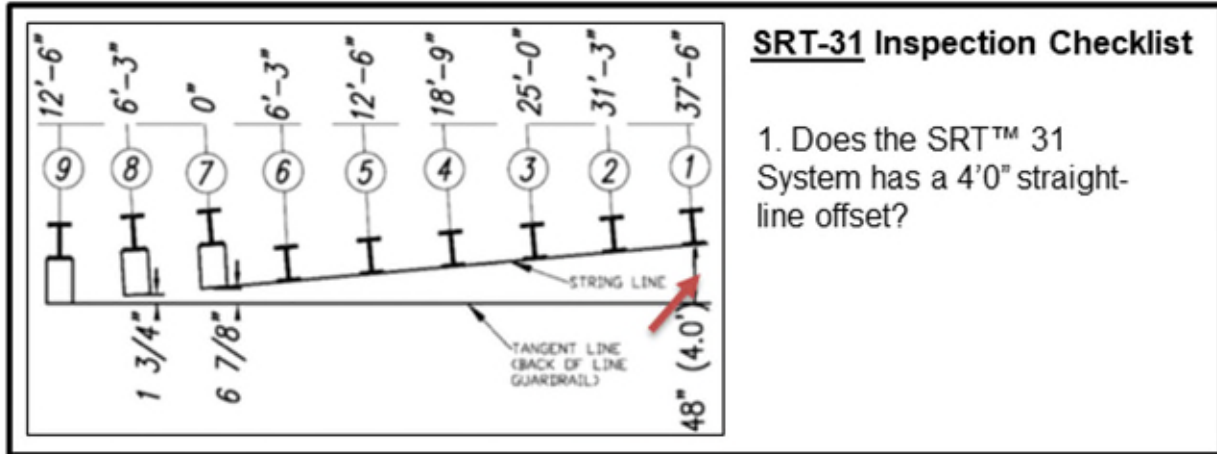

<b>Answer:</b> Yes / No (circle answer)
<b>Correct Checklist Answer:</b> Yes
<b>Manufacturer Checklist Item: #4</b>
Ensure SRT™ 31 System has a 4'0" [1.22 m] straight-line offset. (pp 15-16)



# ON-SITE GUARDRAIL GARDEN TRAINING



**YIELDING HOLE DETAIL  
POST 2-6  
(ELEVATION VIEW)**

**SRT-31 Inspection Checklist**

2. Are the center of the SYTP® yielding holes approximately centered at finished grade line for posts 2 – 6?

<b>Answer:</b> Yes / No (circle answer)
<b>Correct Checklist Answer:</b> Yes
<b>Manufacturer Checklist Item: #5</b>
Ensure the center of the SYTP® yielding holes are approximately centered at finished grade line for posts 2 - 6. (p 17)

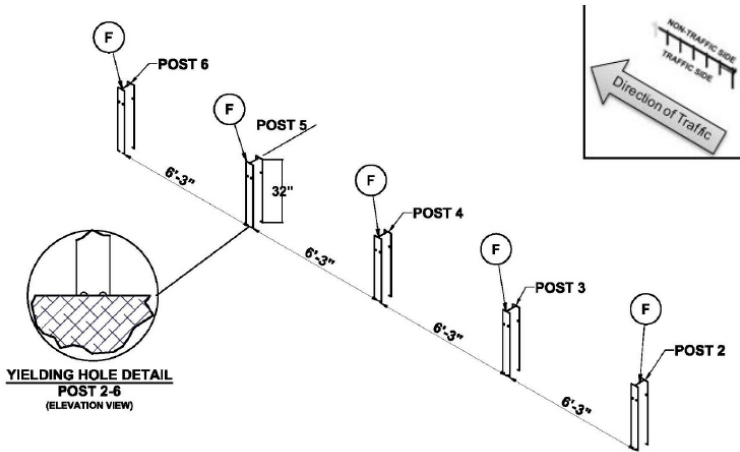

# ON-SITE GUARDRAIL GARDEN TRAINING

 A technical diagram on the left shows a cross-section of a CR Post 1 assembly with callouts 'O', 'E', 'Y', and 'CC'. A red arrow points to the top of the post. To the right is a photograph of the same assembly installed on a guardrail post, with a red arrow pointing to the top of the post.	<b>SRT-31 Inspection Checklist</b>
	3. Are the CR Post 1 top and CR Post 1 bottom oriented correctly?

<b>Answer:</b> Yes / No (circle answer)
<b>Correct Checklist Answer:</b> Yes
<b>Manufacturer Checklist Item: #7</b>
Ensure the CR Post 1 top and CR Post 1 bottom are oriented correctly. (p 20)

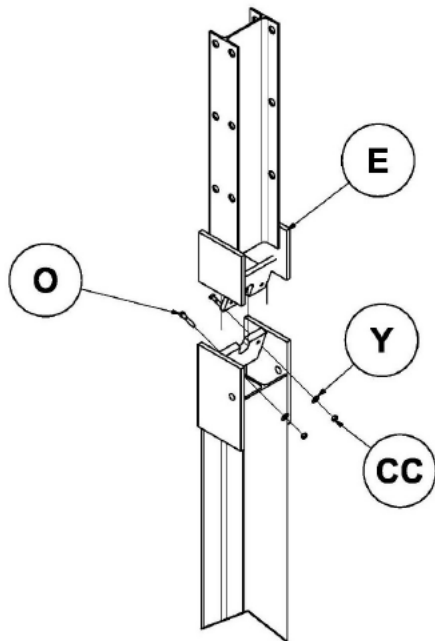

# ON-SITE GUARDRAIL GARDEN TRAINING



## SRT-31 Inspection Checklist

4. Does the top of the CR Post 1 Bottom protrude more than 4" above the finished grade?

**Answer:** Yes / No (circle answer)

**Correct Checklist Answer:** No

**Manufacturer Checklist Item: #8**

Ensure the top of the CR Post 1 Bottom does not protrude more than 4" [100 mm] above the finished grade. (p 19)

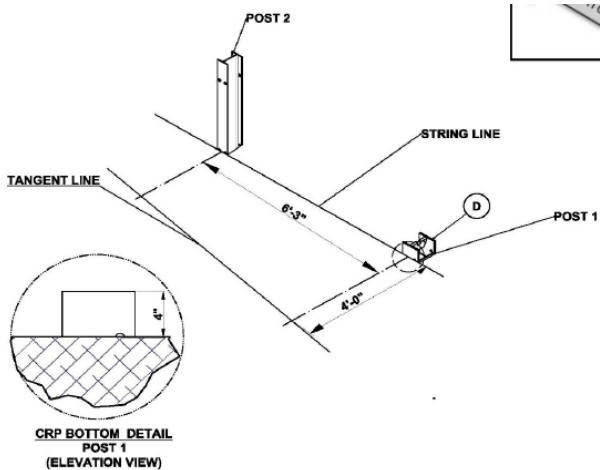

# ON-SITE GUARDRAIL GARDEN TRAINING

		<p><b>SRT-31 Inspection Checklist</b></p>
<p>5. Is the SRT™ Shelf Angle at Post 2 attached with 2 bolts and the SRT™ Flange Protector and SRT™ Anchor Guardrail placed appropriately?</p>		

<p><b>Answer:</b> Yes / No (circle answer)</p>
<p><b>Correct Checklist Answer:</b> Yes</p>
<p><b>Manufacturer Checklist Item:</b> #9</p>
<p>Ensure the SRT™ Shelf Angle at Post 2 is attached with 2 bolts and the SRT™ Flange Protector and SRT™ Anchor Guardrail are placed appropriately. (p 21)</p>

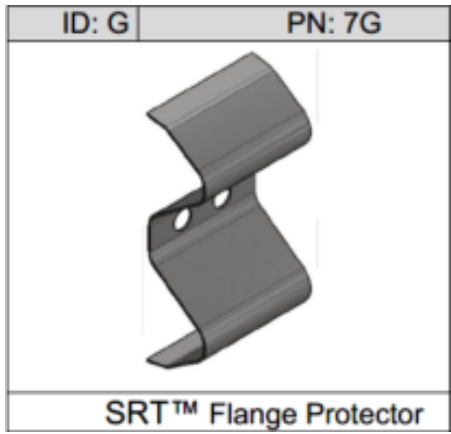

# ON-SITE GUARDRAIL GARDEN TRAINING

**SRT-31 Inspection Checklist**

6. Are SRT™ Flange Protectors installed on traffic side of posts 4 and 6?

<b>Answer:</b> Yes / No (circle answer)
<b>Correct Checklist Answer:</b> Yes
<b>Manufacturer Checklist Item:</b> #11
Ensure the SRT™ Flange Protector is installed on traffic side of post 4. (p 22)

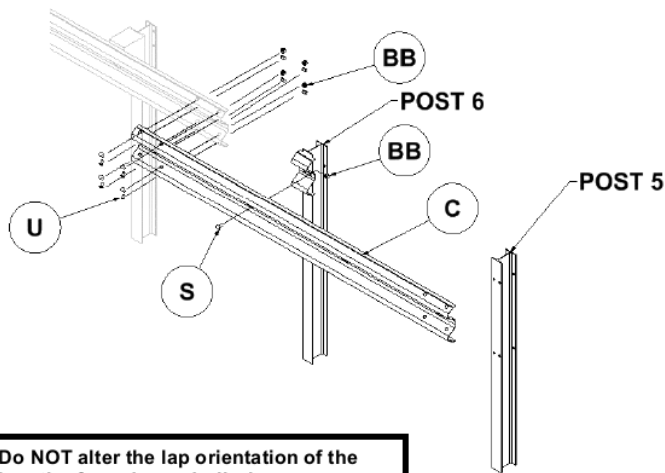

Other Issue: Flange Protectors installed on post 2-6. Manual indicates they should only be on 2,4, and 6.

**Do NOT alter the lap orientation of the length-of-need guardrail when assembling a downstream/trailing end**

# ON-SITE GUARDRAIL GARDEN TRAINING



## SRT-31 Inspection Checklist

7. Are the guardrails between Posts 1 and 7 curved?

**Answer:** Yes / No (circle answer)

**Correct Checklist Answer:** No

**Manufacturer Checklist Item: #12**

Ensure the SRT™-1 Anchor Guardrail and SRT™ -2 and -3 Guardrails between Posts 1 and 7 are not curved. (pp 23- 26)

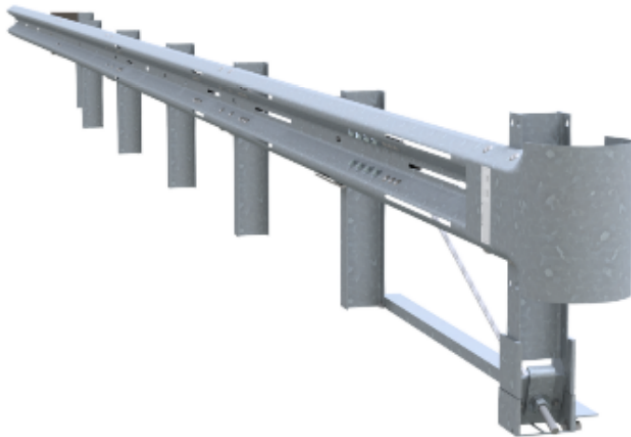

# ON-SITE GUARDRAIL GARDEN TRAINING

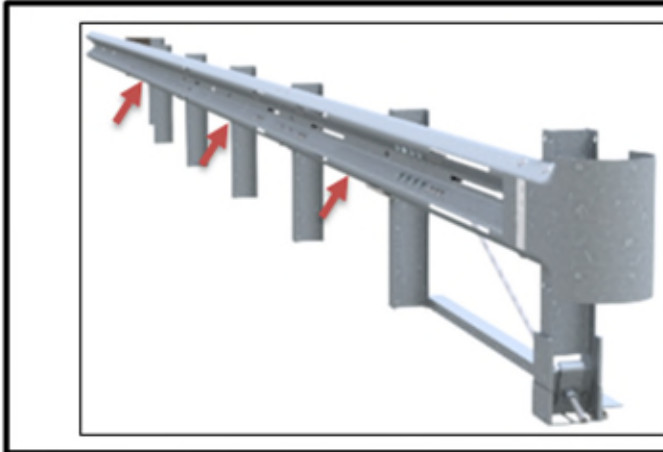

## SRT-31 Inspection Checklist

8. Are the SRT™-1 Anchor Guardrail and SRT™ -2 and -3 Guardrails oriented correctly?

**Answer:** Yes / No (circle answer)

**Correct Checklist Answer:** Yes

**Manufacturer Checklist Item: #13**

Ensure the SRT™-1 Anchor Guardrail and SRT™ -2 and -3 Guardrails are oriented correctly and lapped in the direction of the nearest adjacent traffic. (p 23)

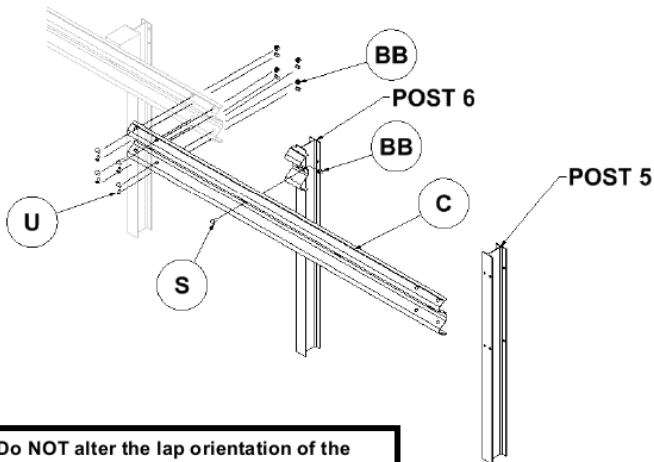

**Do NOT** alter the lap orientation of the length-of-need guardrail when assembling a downstream/trailing end

# ON-SITE GUARDRAIL GARDEN TRAINING

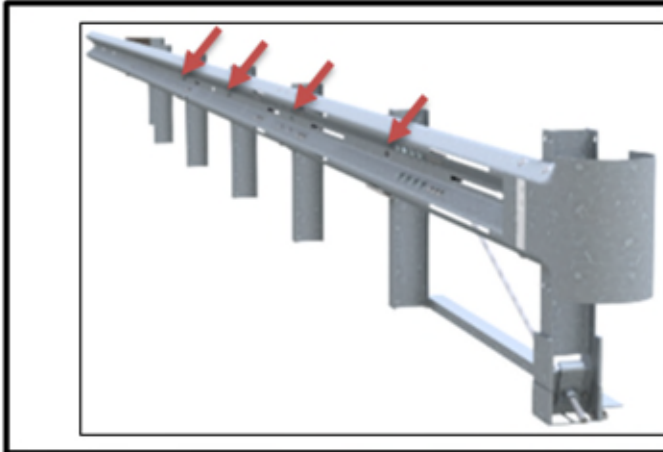

## SRT-31 Inspection Checklist

9. Is the rail bolted to posts 2-5?

**Answer:** Yes / No (circle answer)

**Correct Checklist Answer:** No

**Manufacturer Checklist Item:** #14

Ensure that the SRT™ -2 and -3 Guardrails are not bolted to posts 2-5. (pp 24-26)

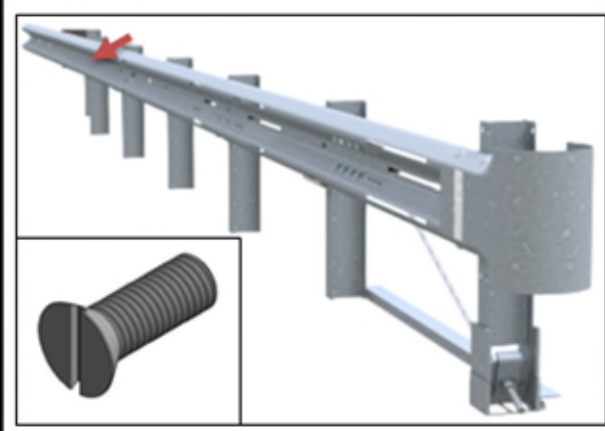

# ON-SITE GUARDRAIL GARDEN TRAINING

	<p><b><u>SRT-31</u> Inspection Checklist</b></p> <p>10. Is the 5/8" x 1.75" countersunk HD bolt used to attach the SRT™-3 Guardrail to Post 6?</p>
---	--

<b>Answer:</b> Yes / No (circle answer)
<b>Correct Checklist Answer:</b> Yes
<b>Manufacturer Checklist Item:</b> #15
Ensure 5/8" x 1.75" countersunk HD bolt is used to attach the SRT™-3 Guardrail to Post 6. (p 24)

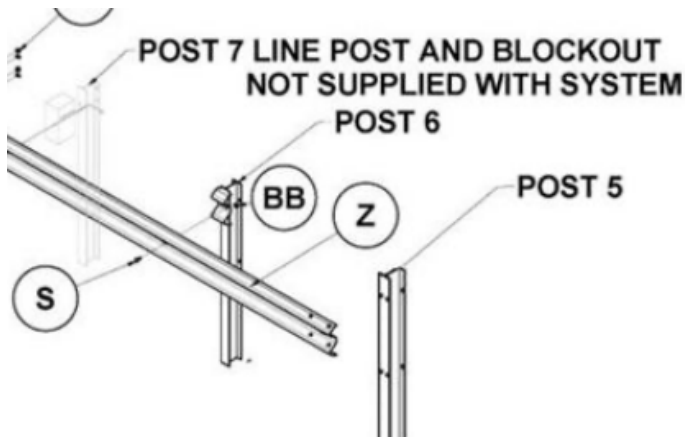

# ON-SITE GUARDRAIL GARDEN TRAINING

## SRT-31 Inspection Checklist

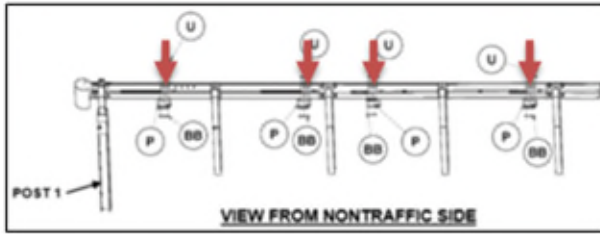

11. Are the SRT™ Slot Guards in place against the non-traffic side of the SRT™ -1 Anchor Guardrail and SRT™ -2 Guardrail with the deflector angle gap opening toward (closest to) the elongated slot and arrows pointing towards Post 1?

**Answer:** Yes / No (circle answer)

**Correct Checklist Answer:** Yes

**Manufacturer Checklist Item: #16**

Ensure the SRT™ Slot Guards are in place against the non-traffic side of the SRT™ -1 Anchor Guardrail and SRT™ -2 and -3 Guardrail with the deflector angle gap opening toward (closest to) the elongated slot and arrows pointing towards Post 1. (p 27)

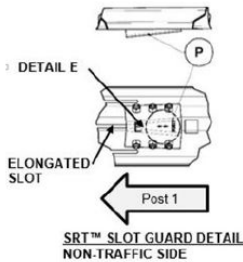
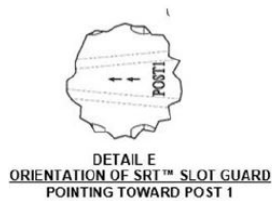

# ON-SITE GUARDRAIL GARDEN TRAINING



## SRT-31 Inspection Checklist

12. Is the SRT™ Cable Anchor Bracket placed between Posts 1 and 2 on the non-traffic side of the SRT™-1 Anchor Guardrail and bolted to the SRT™-1 Anchor Guardrail with eight (8) Hex Bolts and washers?

**Answer:** Yes / No (circle answer)

**Correct Checklist Answer:** Yes

### **Manufacturer Checklist Item: #17**

Ensure the SRT™ Cable Anchor Bracket is placed between Posts 1 and 2 on the non-traffic side of the SRT™-1 Anchor Guardrail and the SRT™ Cable Anchor Bracket is bolted to the SRT™-1 Anchor Guardrail with eight (8) Hex Bolts and that washers are placed between the bolt head and the front of the SRT™-1 Anchor Guardrail. (p 28)

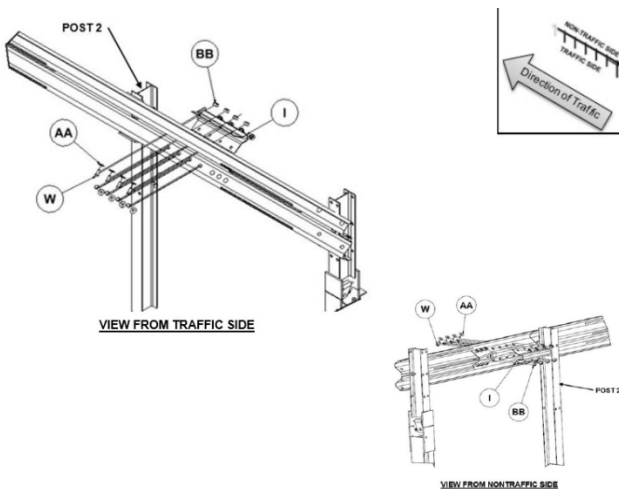

# ON-SITE GUARDRAIL GARDEN TRAINING



## SRT-31 Inspection Checklist

13. Is the bent part of the SRT™ Cable Anchor Bracket Angle at post 1 up and hooked over the CR Post 1 Top?

**Answer:** Yes / No (circle answer)

**Correct Checklist Answer:** Yes

**Manufacturer Checklist Item:** #18

Ensure the bent part of the SRT™ Cable Anchor Bracket Angle [Part Q] at SRT™ Anchor Post is up and hooked over the CR Post 1 Top. (p 28-29)

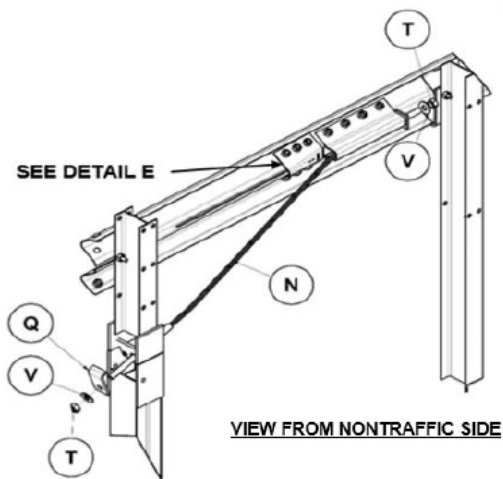

# ON-SITE GUARDRAIL GARDEN TRAINING



## SRT-31 Inspection Checklist

14. Are washers **ONLY** used on the traffic side of the SRT™-1 Anchor Guardrail for the SRT™ Cable Anchor Bracket?

**Answer:** Yes / No (circle answer)

**Correct Checklist Answer:** Yes

**Manufacturer Checklist Item:** #19

Ensure washers are **ONLY** used on the traffic side of the SRT™-1 Anchor Guardrail for the SRT™ Cable Anchor Bracket. (p 28)

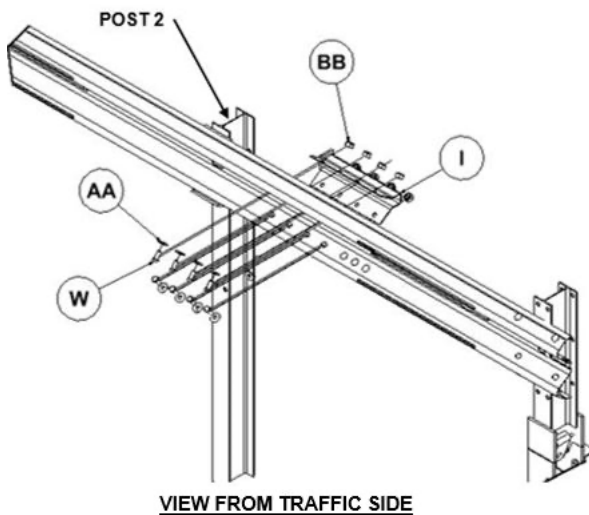

# ON-SITE GUARDRAIL GARDEN TRAINING



## SRT-31 Inspection Checklist

15. Are the 1" Hex Nuts fully tightened and the SRT™ Anchor Cable taut?

**Answer:** Yes / No (circle answer)

**Correct Checklist Answer:** Yes

**Manufacturer Checklist Item:** #20

Ensure the 1" Hex Nuts have been fully tightened and the SRT™ Anchor Cable is taut. (p 29)

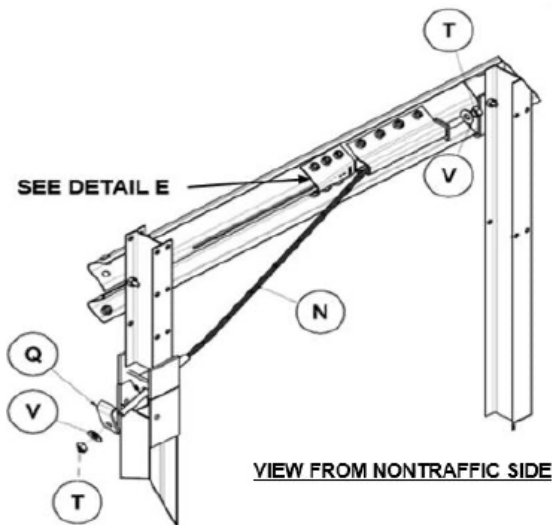

# ON-SITE GUARDRAIL GARDEN TRAINING



## SRT-31 Inspection Checklist

16. Is the SRT™ Angle Strut properly attached on the non-traffic side to the CR Post 1 Bottom and Post 2 SYTP®?

**Answer:** Yes / No (circle answer)

**Correct Checklist Answer:** Yes

**Manufacturer Checklist Item: #21**

Ensure the SRT™ Angle Strut is properly attached on the non-traffic side to the CR Post 1 Bottom and Post 2 SYTP® . (p 30)

